

USER MANUAL

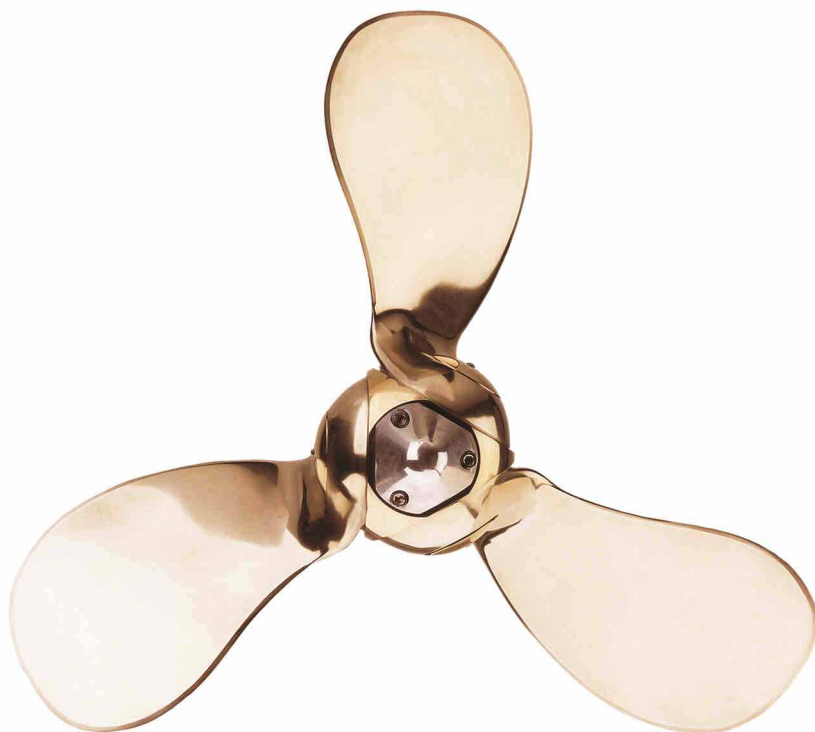

AUTOPROP

Automatic Variable Pitch Propellers Since 1986

Autoprop serial No.

H6

FITTING, REMOVAL AND MAINTENANCE OF H6 MODEL 3 BLADE AUTOPROP

The Autoprop is supplied assembled, tested, and ready to fit to your yacht. Observing the following notes will ensure correct fitting and trouble free service. Additional information and video instructions are available on the Bruntons' You Tube page. Just type 'how to fit an Autoprop' into your web browser.

Disclaimers

All information in this fitting and maintenance manual are based on the information available at the time of publishing. The diagrams are for reference only and help explain the make-up of your Autoprop. Our description of the parts and instructions are there to help you maintain and service your Autoprop.

Tools required for maintenance and fitting/removal

- Selection of Allen keys
- Small flat blade screwdriver
- Socket spanner for propeller shaft nut
- Propeller extractor tool. (Bruntons special tool for Autoprop removal)
- Loctite (thread locking compound) supplied

Spare Parts

- Zinc anode with screws
- Bearing service kit
- Individual components
- Blade fitting and removal Instructions
- Corrosion resistant waterproof grease. USE ONLY BRUNTONS' APPROVED GREASE

- Grease gun
- Greasing nozzle (supplied with Autoprop)
- Replacement blades

Fitting

Before fitting your new Autoprop ensure that the cutlass bearing is not worn. A worn bearing will not be suitable for any propeller. If it is worn replace it with a good quality bearing, preferably with a brass shell.

1. After removing the old propeller check that the shaft taper, key, and thread are undamaged. Try the new shaft nut on to the thread. The taper should be clean and dry. Check that the key will slide through the keyway in the Autoprop without jamming at any point.
2. Fit the key into its seat on the shaft. Push the Autoprop on to the shaft making sure it fits snugly on the taper. If it does not appear to fit well, there may be some foreign objects on the taper, or you may need to file the key down until the Autoprop fits snugly on to the taper.
3. Screw the new shaft nut up tight using a socket spanner, finishing with one of the flats of the nut coming under the shaft nut locking screw. If the shaft nut locking screw will bear on to the body of the shaft nut you will need to dimple the body of the shaft nut, with a drill or punch.
4. Smear the thread of the shaft nut locking screw with thread locking compound and screw it down on to the shaft nut.

5. Hold the anode nose cone in place and screw down to fit. Do not over tighten.

Your Autoprop is now ready for use

Removal

1. We recommend that you use a special extractor available from your Autoprop supplier. This is simple to use and avoids having to remove the rope cutter, if fitted. Most three legged pullers will also fit the Autoprop.
2. Remove the anode nose cone by removing the nylon screws.
3. Unscrew the shafts nut locking screw (10) until it is clear of the shaft nut.
4. Unscrew the shafts nut remembering whether it has a right or left hand thread.
5. You can now use your three legged puller to remove your Autoprop from the shaft. With the Brunton's extractor tool, screw the extractor plate on to the end of the propeller boss using the socket head screws provided. Screw in the jacking screw and tighten until the Autoprop loosens on the taper, and remove from the shaft.
6. Tape the key on to the shaft, or remove and keep in a safe place.

AUTOPROP MAINTENANCE

Your new AVP Autoprop is fitted with greasing channels in each blade; therefore blade removal is not necessary in order to re-grease your Autoprop. The Autoprop needs to be re-greased once every year. Alternatively grease whenever you haul the boat for annual maintenance.

The Autoprop needs good protection from electrolytic and chemical corrosion. Ensure that you replace the anode each year. For extra protection it is advisable to fit a shaft anode or shaft brushes, as the Autoprop anode will only protect the Autoprop.

The bearings should not need replacement for upwards of 1500 to 1800 engine hours, depending on power of your engine and usage. It may be prudent to check the bearings and the seals after 1200 engine hours or 4 to 5 seasons. Eventually, the bearings will need replacing. This is a straightforward procedure covered in the maintenance sheet supplied with our bearing kit. To order this kit simply contact your Autoprop distributor or visit our shop online www.bruntonpropellers.com

GREASING YOUR AUTOPROPS BEARINGS

You will see these channels on the blade palm situated near the bearing mechanism (7). Inserted into a 5mm diameter hole you will find a pan head screw, which is fastened into the blade using an Allen key. The retaining cap (1) facilitates a grease exit hole sealed with a pan head socket screw and this also needs to be removed when greasing. O-rings are fitted to these greasing channel screws. Always use good quality Lithium waterproof grease as supplied by your Autoprop distributor. We recommend **SKF LGWA 2/A4**

A special grease nipple is supplied with your Autoprop that fits into the greasing channel. This nipple will attach to a hose type grease gun.

H6 greasing procedure

1. Remove the pan head screws from the grease channel (7) on the blade.
2. Fit the grease nipple by screwing it into the grease channel (7) on the blade and connect to the grease gun.
3. Remove the grease exit screw (1) in the retaining cap.
4. Your hub can now be applied with the grease. Pump the gun until the new grease pushes through the grease exit hole. You may need to rotate the blade, working the new grease around the bearing.
5. Clean any excess grease from the retaining cap and replace the pan head screw (1) with the o-ring.

6. Remove the grease nipple and clean the excess grease and replace the grease channel screw.
7. Ensure that all three blades are greased as per instructions.

LAYING-UP

Whenever you haul-out for antifouling or laying-up for example, the Autoprop needs to be given a high pressure wash before it has a chance to dry out. This will remove any deposits or growth from the propeller. After this, rotate the blades by hand to ensure they are free moving. At this stage re- greasing can be carried out to the Autoprop. **Ensure that you grease the Autoprop bearings before laying up your yacht for a long period.**



Automatic Variable Pitch

The Autoprop's blades are custom designed by Brunton's Propellers for the particular power, shaft revolutions, and vessel speed. The components of hydrodynamic and centrifugal forces balance, to set the blades at the correct pitch angle. As the yacht speed or engine revolutions change, the blades will automatically readjust to keep the optimum angle of attack to the water flow at all time.

Feathering your Autoprop under sail

Follow the instructions in your engine manual or operators guide for use of folding and feathering propellers. With engines fitted with hydraulic gearboxes, engage your shaft lock. Your Autoprop distributor will be able to advise you if this is necessary. Details of the Autolock manufactured by Brunton's Propellers are available on request.

Water Intrusion (wet exhaust system)

On long distance passages and especially when sailing in a rough sea state with a following sea, you must ensure that the vessels exhaust system is protected from being overfilled. In addition to this, the water cooling inlet should always be shut at sea and only opened when required. This is especially important when sailing at high speeds, particularly on catamarans. Further instructions should be available from your engine operator's manual. It is vitally important that your wet exhaust system installation meets the necessary requirements to prevent any damage to your engine in the unlikely event of water intrusion.

Anodes and corrosion prevention

You must ensure that your yacht uses a proper galvanic corrosion system to reduce and regulate the attack of any exposed metals onboard, including the propeller. The boat operator must frequently monitor the wear of the anodes on the propeller and on the yacht. It is particularly important to monitor corrosion when alongside the dock or berthed in a marina for long periods, and especially when connected to shore power. The Marina

environment can be more active with low voltage DC current leaks or stray currents. Galvanic corrosion should be prevented with the use of an isolation transformer or galvanic isolator. This device offers protection from stray currents and galvanic currents which can attack your boat via the shore power earth cable. Without it anodes and zincs will rapidly wear out leaving your propeller exposed to galvanic corrosion.

Heavily fouled Autoprop blades

The performance of the Autoprop will be impaired by marine growth just as any conventional propeller. With heavy fouling, thrust diminishes, and there is a reduction in the maximum engine revolutions attainable. However, the Autoprop will still pitch correctly. In areas of high fouling, smoothly coating the Autoprop with a high quality marine antifouling may help to reduce the amount of growth.

Manoeuvring characteristics of the Autoprop?

Due to the self pitching action of the Autoprop, manoeuvring is different to conventional propellers. Firstly, in most cases, there is noticeably less 'prop-walk' experienced. This is due to the finer pitch setting at low speeds giving a reduced 'paddle wheel' effect. Secondly, due to this finer pitch, at low speeds there is less 'bite' felt when engaging ahead or astern from a standstill. This means that more engine revolutions than normal should be used when moving off from a standstill, or at very low speeds. Once some speed has been attained, the engine revolutions may be reduced.

This unique feature of the Autoprop, enables the full power of the engine to be used in situations such as towing, or in emergencies. With conventional propellers the pitch is too

coarse at very low speeds, the engine cannot achieve its full revolutions, and therefore full thrust is not achievable.

Damaging your Autoprop

The Autoprop is some 40% stronger than conventional propellers, as it is made from a special high grade bronze alloy called Superston. The high resistance to impact damage means that you are less likely to damage the Autoprop. In the unlikely event that a blade becomes damaged, you only need to replace that blade, and not the complete Autoprop.

Fitting a new engine or gearbox with the Autoprop

You may fit a rope cutter with the Autoprop in the same way as any other propeller. Follow the manufacturer's fitting instructions for or three bladed propellers. With conventional propellers you need to dismantle the rope cutter in order to use a puller for propeller removal. Although you can use most conventional three legged pullers to remove the Autoprop, with Brunton's Propellers purpose made puller there is no need to disturb the rope cutter.

Fitting a rope cutter with the Autoprop

You may fit a rope cutter with the Autoprop in the same way as any other propeller. Follow the manufacturer's fitting instructions for or three bladed propellers.

With conventional propellers you need to dismantle the rope cutter in order to use a puller for propeller removal. Although you can use most conventional three legged pullers to remove the Autoprop, with Brunton's Propellers purpose made puller there is no need to disturb the rope cutter.

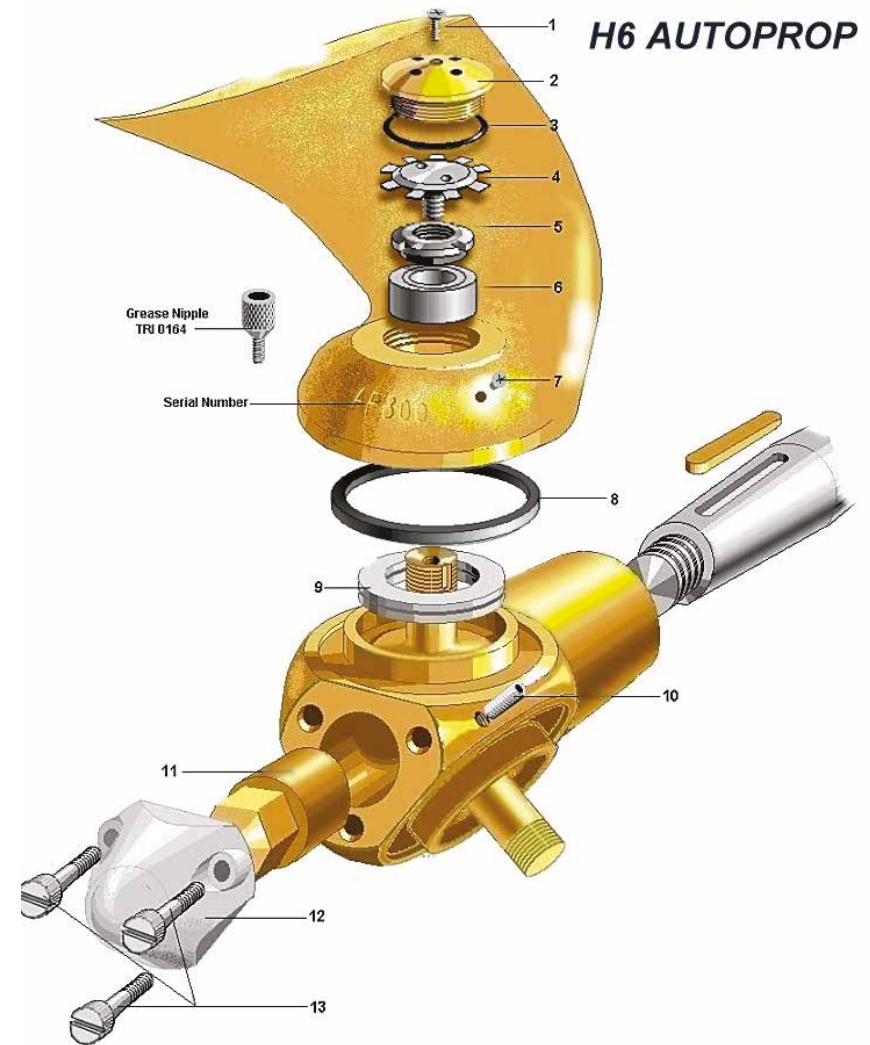

Position	Part No	Qty	Description
1&7	M5X6BUTHDSSA4	6	M5 x 6.0mm Button head Screw Stainless Steel A4
2	H6RBC	3	H6 Roller Bearing - Bearing Retaining Cap
3	M40.00X02.50'O'RINGNITRILE70	3	40.0mm Inner Diameter x 2.5mm Section "O" Ring Nitrile 70 Shore
4	H6RBTS	3	H6 Roller Bearing Tab Screw
5	H6TSLN	3	H6 Tabscrew Locking Nut
6	BEARING32004X	3	Taper Roller Bearing 32004X
8	H6LS	3	H6 Roller Bearing Autoprop Seal
9	BEARING51110	3	Thrust Race Bearing 51110
10	Identified with AP serial No only	1	M10 shaft Nut locking Grub screw
11	Identified with AP serial No only	1	Shaft Nut
12	H6AN	1	H6 Zinc Anode
13	M8X16CHHDNY	3	M8 x 16.0mm Cheese Head Screw Nylon



Autoprop Periodic Maintenance

Your Autoprop has been manufactured from the finest marine grade materials using the latest engineering techniques together with an advanced quality control process to ensure trouble free performance for your enjoyment. To keep your propeller in fine form and 100% reliable, it is highly recommended that your propeller is serviced and maintained as described in our fitting and maintenance instruction book.

You can carry out a basic service yourself, particularly for greasing the blades and zinc anode replacement. We do advise that you use original parts, as well as our recommended grease. These parts are available through our network or world-wide sales outlets.

For prescribed manufacturers recommended bearing and seal replacement. It is highly recommended to use a trained technician or a Brunton's Propellers Authorized Service Centre. Details of approved service centres are available on our website.

Thank you for choosing the World's only Automatic Variable Pitch propeller for your propulsion package. Happy Sailing.



Service 1	Service 2
Date	Date
Engine Hours	Engine Hours
Service Centre	Service Centre

Service 11	Service 12
Date	Date
Engine Hours	Engine Hours
Service Centre	Service Centre

Service 3	Service 4
Date	Date
Engine Hours	Engine Hours
Service Centre	Service Centre

Service 13	Service 14
Date	Date
Engine Hours	Engine Hours
Service Centre	Service Centre

Service 5	Service 6
Date	Date
Engine Hours	Engine Hours
Service Centre	Service Centre

Service 15	Service 16
Date	Date
Engine Hours	Engine Hours
Service Centre	Service Centre

Service 7	Service 8
Date	Date
Engine Hours	Engine Hours
Service Centre	Service Centre

Service 17	Service 18
Date	Date
Engine Hours	Engine Hours
Service Centre	Service Centre

Service 9	Service 10
Date	Date
Engine Hours	Engine Hours
Service Centre	Service Centre

Service 19	Service 20
Date	Date
Engine Hours	Engine Hours
Service Centre	Service Centre

TERMS & CONDITIONS OF WARRANTY AND PRODUCT LIABILITY

DEFINITIONS

These Conditions shall be incorporated in all Contracts entered into by Bruntons Propellers Ltd ("Company") to the exclusion of any other terms and conditions whether or not the same are endorsed upon, delivered with or referred to in any purchase order or other document delivered by the Purchaser to the Company.

REPAIR, SERVICING & OTHER WORKS

In the event of the Company undertaking the repair or servicing or any other work (whether of a similar nature or not) on goods made available for the purpose by a Purchaser:

Every care will be taken to carry out the work satisfactorily but no guarantee is given to return goods to their original state or as to their performance, nor is any liability accepted in connection with the time taken to carry out the work;

The Purchaser or his agents shall give the Company or its workmen or those of its agents access to any dock and ship or other premises where the goods are situated and to the goods to be worked on at all reasonable times with the use of normal dock or other services including air, water and electricity. If the Company consider it necessary to work outside normal hours the Purchaser will use his best endeavour to facilitate such work and to provide the necessary access and services.

DAMAGE IN TRANSIT

When the price quoted includes delivery the Company will repair or replace free of charge goods damaged in transit provided the carriers and the Company receive written notification of such damage within seven days of delivery. The Company shall not be responsible for any damage sustained after the goods have been unloaded at the agreed point of delivery of where the Purchaser has failed to notify the Company of the damage within the time period specified.

SPECIFICATION AND PERFORMANCE

Unless the Company has been engaged to produce technical drawings only, all specifications, drawings and other data submitted with a tender or quotation are approximate. Descriptions and illustrations contained in catalogues, prices lists and other advertising matter issued by the Company are intended only to present a general idea of the goods and none of these documents shall form part of any contract unless expressly stated.

1. Unless otherwise agreed by the parties, any drawings, specifications and other data issued by the Company for the purpose of any contract or prospective contract

remain the property of the Company and shall be treated as confidential by the Purchaser.

2. Performance figures given are based upon experience and are such as the Company expects to obtain on test. The Company accepts no liability if such performance is not attained in use unless it is expressly guaranteed in the contract. Where such guarantee is given it shall be without prejudice to the provisions of Clause 15 thereof.
3. It is the Purchaser's responsibility to satisfy themselves that the specification offered by the Company defines goods which are sufficient and suitable for the Purchaser's purpose. Defects in quality or dimensions in any delivery shall not be grounds for cancellation of the remainder of the order or contract (if any).

INTELLECTUAL PROPERTY RIGHTS

Unless expressly stated to the contrary and embodied in the contract, all intellectual property rights in respect of the goods and services remain vested in the Company.

1. Where goods are not of the Company's design the Purchaser shall indemnify the Company against all damages, penalties, costs, claims and liability in respect of the infringement of any letters patent registered design or other industrial rights resulting from the carrying out of work in accordance with his design particulars specifications work data or instructions, express or implied.

DELIVERY TAKING OVER AND PASSING OF PROPERTY

Without prejudice to any of the Company's other rights under these terms and conditions notwithstanding delivery of any goods and at the Company's sole discretion, title in the goods shall remain with the Company until they have been paid for in full.

1. If such payment is overdue in whole or in part the Company may (without prejudice to any of its other rights) recover or re-sell the goods or any of them and may enter upon your premises for that purpose, a licence for which purpose is hereby granted, if any of the goods are incorporated in other goods before such payment the Property in the goods delivery by the Company shall nevertheless be and remain with the Company until such payment has been made provided that where any goods delivered under this Contract have been sold by the Purchaser either in their original form or after further processing or incorporating in some products then the Purchaser shall be trustee for the Company of the proceeds of sale thereof or of any claim by the Purchaser in respect of such goods.
2. Notwithstanding the above, risk in the goods shall pass to the Purchaser upon delivery (and you should therefore insure).

PACKAGING

Unless otherwise stated packaging will be in accordance with the Company's standard packaging and is not returnable.

1. The Company accepts no liability whatsoever for damage in transit on the grounds of alleged unsuitability of packaging.

GUARANTEE

1. The Company undertakes during a period of twelve months from the date of delivery and provided the goods have been subject to proper use and storage to replace or at its option repair at a location of its choice goods which prove to be defective due to faulty materials or workmanship. The guarantee is given in lieu of any liability or guarantee implied by law in respect of the liability of the Company.
2. Defective items or parts thereof must be promptly returned to a location chosen by the Company. If the defect is found to have arisen under conditions covered by this guarantee then the Company will repair or replace the defective part and send the repaired or replacement part free of charge. If, however, the goods are found either to be serviceable or to be defective for reasons outside the guarantee then, the entire costs of the test repair or replacement and carriage shall be borne by the Purchaser. The Company decision as to whether or not a defecation is covered by this guarantee or not shall be final and binding on both parties.
3. In respect of parts of components with a finite life not manufactured by the Company the Purchaser shall receive only such guarantee as shall be given by the manufacturer or supplier thereof to the Company.
4. The benefits of sub-clause .1 and .2 shall apply to any goods repaired or replaced in accordance with the terms hereof.
5. The Company shall have no responsibility for goods or parts thereof altered by the Purchaser without the Company's express written agreement or exhibiting wear or suffering damage before the expiration of the Company's guarantee period due wholly or partially to improper or careless treatment or operation, excessive stressing, sandy or polluted water, deposit of or intrusion of extraneous bodies, or defective shipbuilding or machinery installation work, or for defects caused by or causing or contributing to vibration characteristics of a ship or engine.
6. In the event of the Company providing a member of its engineering staff to attend at the installation of a propeller manufactured or repaired by it, it is to be understood that except as otherwise agreed in writing with the Company any advice and/or assistance will be given in good faith but without any acceptance of responsibility.

7. Normal wear and tear will not be covered under warranty.
8. Parts not serviced correctly in the prescribed time frame with OEM parts, tools and grease, will be void of warranty.

TESTS

Goods if manufactured by the Company and requiring tests or inspection shall be tested at a place nominated by the Company. If the Purchaser or his representative does not attend, the Company will have the test or inspection carried out in accordance with the specification and the Purchaser shall be deemed to have accepted such test or inspection. If any additional or special tests by more than one Classification Society or Inspection Authority are required, the extra costs shall be borne by the Purchaser.

LIMITATION ON LIABILITY

The Company does not accept, and the Client indemnifies the Company against, any consequential loss and liability whatsoever, howsoever arising, directly or indirectly, from the provision of work, goods or services under the Contract.

1. The Company shall be liable for general damages to the Customer's arising, directly or indirectly, from the provision of work, goods or services under the Contract. The Company's liability in respect of such damage shall in every respect, unless otherwise agreed in writing by the Company, be limited to 25% of the value of the work, goods or services provided under the terms of the Contract.

HEALTH AND SAFETY INDEMNITY

1. The Purchaser shall indemnify the Company in respect of any liability, monetary penalty or fine in respect of, or in connection with the Products incurred by the Company under the Health and Safety at Work Act 1974 or any statutory modification or re-enactment thereof or any regulations, orders or direction made thereunder.

JURISDICTION

1. All Contracts shall be construed in accordance with English Law and all disputes which may arise under or in connection with the Contract shall be submitted to arbitration in accordance with the Arbitration Act 1950 and any statutory modification or re-enactment thereof.

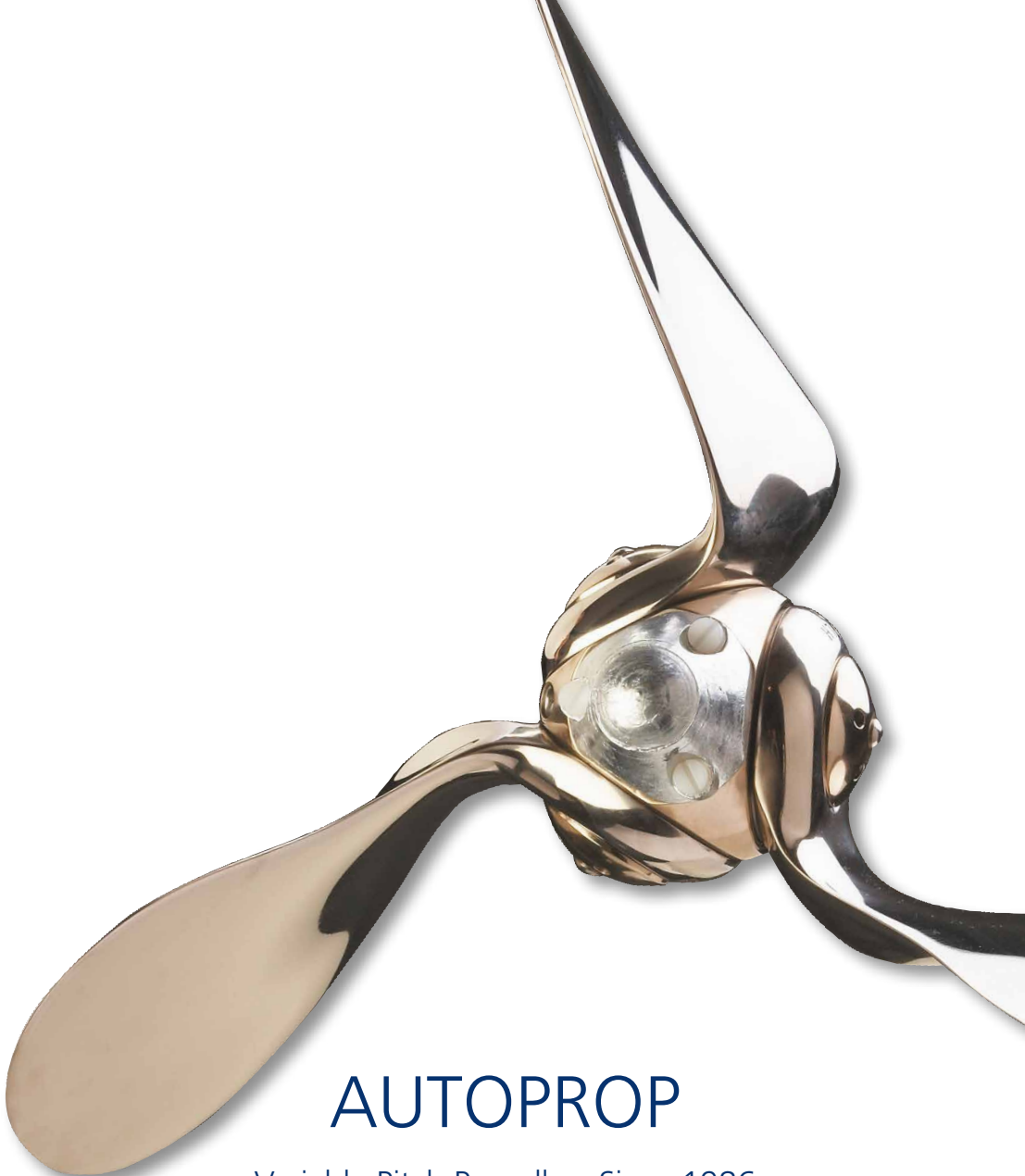

AUTOPROP

Variable Pitch Propellers Since 1986

Bruntons Propellers Ltd

T: +44 (0)1255 420005 E: sales@bruntons-propellers.com W: www.bruntonspellers.com

Oakwood Business Park, Stephenson Road West, Clacton-on-Sea, Essex, CO15 4TL, UK